

Product	Category	Benefits	Technology	ISO viscosity grades	Specifications and approvals <small>(Full details of approvals for all products can be obtained from your Shell representative; approvals and claims will vary by viscosity grade.)</small>
Shell Turbo GT	Heavy-duty gas turbines and turbocompressors	<ul style="list-style-type: none"> <li>■ Extra long life</li> <li>■ High efficiency</li> </ul>	Synthetic oil	32	Approved by or meets Siemens TLV 9013 04; Alstom HTGD 90-117 V; GEK 27070, 28143A, 46506E, 32568f and 107395a; Siemens Westinghouse 55125Z3; GEC Alstom NBA 50001A; Solar ES 9-224W Class II; DIN 51515 Parts 1 (L-TD) and 2 (L-TG); ISO 8068; JIS K-2213 Type 2; ASTM D4304-06a Type I and III; and BS 489:1999
Shell Turbo CC	Industrial steam, gas and combined-cycle turbines, including geared systems	<ul style="list-style-type: none"> <li>■ Extra long life</li> <li>■ Extra protection</li> </ul>	Mineral oil	32, 46	Approved by or meets Siemens TLV 9013 04; Alstom HTGD 90-117 V; GEK 27070, 28143A, 46506E, 32568f, 32568A and 107395a; Siemens Westinghouse 55125Z3; GEC Alstom NBA 50001A; Solar ES 9-224W Class II; DIN 51515 Parts 1 (L-TD) and 2 (L-TG); ISO 8068; JIS K-2213 Type 2; ASTM D4304-06a Type I, II (EP); and III; BS 489:1999
Shell Turbo T	Industrial steam and light-duty gas turbines and turbocompressors	<ul style="list-style-type: none"> <li>■ Reliable performance</li> <li>■ Reliable protection</li> </ul>	Mineral oil	32, 46, 68, 100	Approved by or meets Siemens TLV 9013 04; Alstom HTGD 90-117 V; MAN Turbo SPD 10000494596; MAG Cincinnati P-38, P-55 and P-54 (appropriate viscosity grade); GEK 27070, 28143A, 46506E, 32568f and 107395a; Siemens Westinghouse 55125Z3; GEC Alstom NBA 50001A; Solar ES 9-224W Class II; DIN 51515 Parts 1 (L-TD) and 2 (L-TG); ISO 8068; JIS K-2213 Type 2; ASTM D4304-06a Type I and III; and BS 489:1999
Shell Turbo J	Industrial steam and light-duty gas turbines and turbocompressors	<ul style="list-style-type: none"> <li>■ Reliable performance</li> <li>■ Reliable protection</li> </ul>	Mineral oil	32, 46	Meets the following MHI specifications: Turbine Oil Type 2 (additive); MS04-MA-CL001 (R-1); MS04-MA-CL002 (R-1).

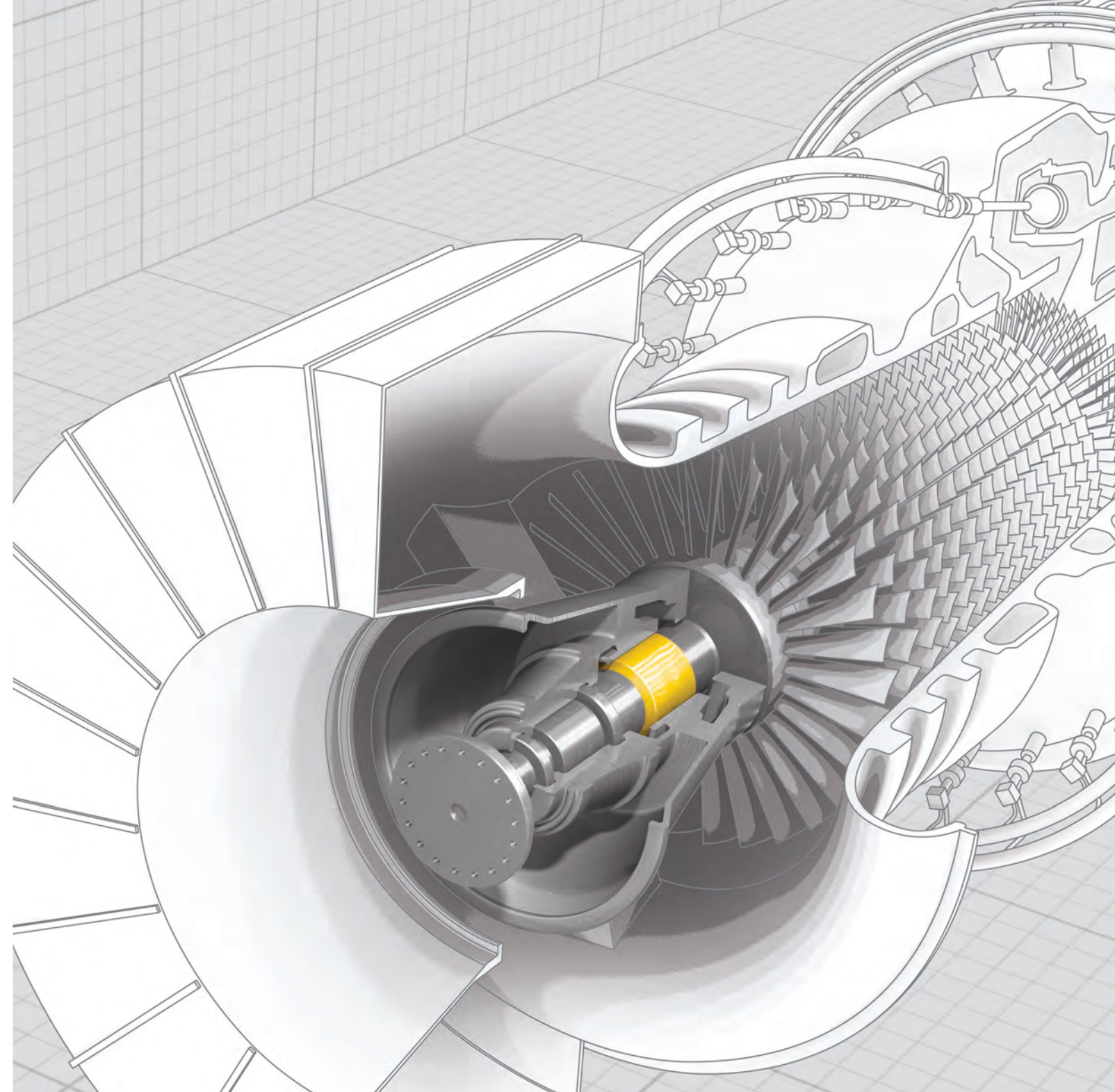

### FULL PRODUCT AND SERVICE PORTFOLIO

Shell Lubricants is named the market leader in lubricants [Kline & Company 2009] and has a 60-year history of innovation. We are constantly investing to develop better lubrication solutions, as demonstrated by

- Shell Diala S3 ZX-I – a premium, inhibited electrical insulating oil
- Shell Turbo DR – a fire-resistant, synthetic turbine oil.

In addition, Shell provides the excellent Shell LubeAnalyst oil condition monitoring service, which is designed to help you improve your business performance.

Whatever your needs or application, Shell can provide a full range of oils and greases, including synthetic, high-performance products and additional services.

**DESIGNED TO DELIVER  
RELIABILITY AND EFFICIENCY.**

**JUST LIKE OUR TURBINE OILS –  
SHELL TURBO.**

**DESIGNED TO MEET CHALLENGES**

For more information, please contact



[shell.com/lubricants](http://shell.com/lubricants)





**EVERY PART OF YOUR MACHINE OR PROCESS HAS BEEN METICULOUSLY ENGINEERED, SO YOU WANT TO BE SURE THAT YOU CHOOSE A LUBRICANT THAT HAS BEEN DESIGNED TO ENSURE THAT YOUR EQUIPMENT IS WELL PROTECTED AND WORKS EFFICIENTLY.**

Shell has developed a range of turbine oils that enables users such as power companies and process plant operators to select the oil that will deliver optimum value to their operations through enhanced protection, long oil life and high system efficiency.

**SYSTEM PROTECTION**

From high-temperature gas turbine systems to combined-cycle systems with integral gearing, the Shell Turbo range of turbine oils is designed to protect your equipment from the effects of corrosion and to minimise the build-up of deposits and lacquer in turbine bearings and control valves. It includes Shell Turbo CC, which is specifically formulated to provide additional protection for gearboxes in turbine systems that require enhanced anti-wear performance from the oil.

**OIL LIFE**

Because Shell understands the costs that downtime can incur in a capital-intensive plant, its lubricants are designed for exceptional oil life under continuous operating conditions. The products are designed to ensure outstanding oxidative stability and to resist the effects of water contamination. Shell's manufacturing processes are tightly controlled to ensure that customers receive only the highest-quality lubricants.

**SYSTEM EFFICIENCY**

To help your turbines to perform to their full operating potential, the Shell Turbo range of turbine oils is designed to have rapid air release and excellent filterability characteristics.





**A RANGE OF TURBINE OILS DESIGNED TO MEET YOUR NEEDS**

To meet the challenges of a wide range of equipment designs and applications, Shell has designed a portfolio of oils that enables you to choose a product to best match your technical and operational needs.

**PRODUCT-NAME SUFFIX KEY**

- GT** = Gas turbines
- CC** = Combined-cycle turbines
- T** = Steam, hydro turbines

**APPLICATION ICON KEY**

-  Turbine
-  Power station
-  High temperature
-  Turbo compressor
-  Enclosed gear

**HEAVY-DUTY GAS TURBINES AND TURBOCOMPRESSORS**

**INDUSTRIAL STEAM, HEAVY-DUTY GAS AND COMBINED-CYCLE TURBINES, INCLUDING GEARED SYSTEMS**

**INDUSTRIAL STEAM AND LIGHT-DUTY GAS TURBINES AND TURBOCOMPRESSORS**

**INCREASINGLY EFFICIENT PROTECTION**

**ADVANCED TIER 4**  
**PREMIUM TIER 3**  
**MAIN LINE TIER 2**

**Shell Turbo GT**

**SYNTHETIC**

- Extra long life
- High temperature operation



**Shell Turbo CC**

- Extra long life
- Extra protection



**Shell Turbo T**

- Reliable performance
- Reliable protection



**Shell Turbo J**

- Satisfies requirements of MHI steam and gas turbines

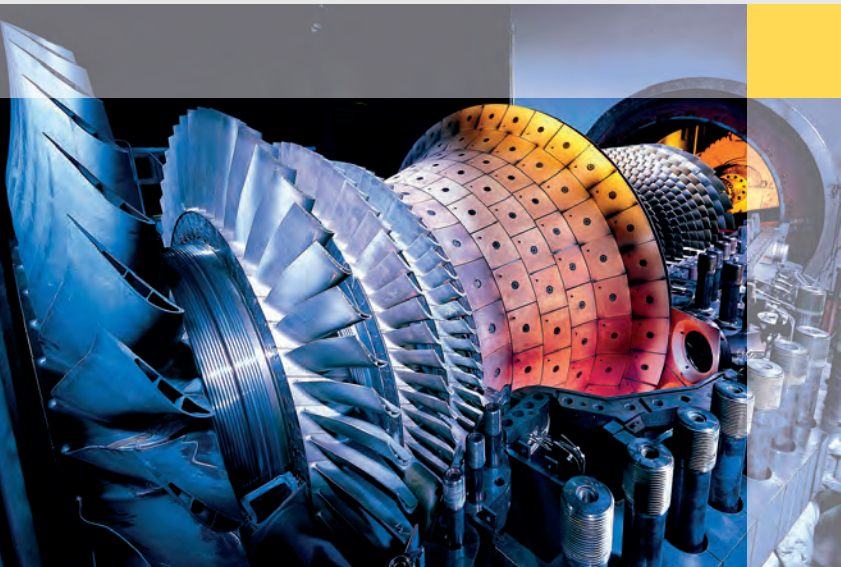
**SHELL SERVICES FOR POWER COMPANIES**

The Shell offer extends beyond oil products. It also includes services such as support with commissioning, flushing, filling and filtration, and ongoing oil condition monitoring, which can help you to run your operation as efficiently and cost-effectively as possible.

**REAL-WORLD VALUE DELIVERY**

**Extended oil life**

By switching from a competitor product to a Shell Turbo oil, one customer reportedly

- increased the oil-drain interval
- reduced lubricant and maintenance costs
- enhanced production capability.

In total, the customer reported that this was worth around \$60,000<sup>1</sup> a year.

<sup>1</sup> Saving reported by one customer. Actual savings may vary, depending on the application, the current oil used, the maintenance procedures and the condition of the equipment.

**Enhanced system efficiency**

After suffering a series of operational issues, one turbine operator switched to a Shell Turbo oil. This

- reduced journal bearing failures
- extended the bearing life
- improved plant reliability.

In total, the customer reported that this cut operating costs by 37%.